

## Modular Cooking Range Line EVO900 Gas Bratt Pan 100lt with Duomat bottom

ITEM # \_\_\_\_\_

MODEL # \_\_\_\_\_

NAME # \_\_\_\_\_

SIS # \_\_\_\_\_

AIA # \_\_\_\_\_



392427 (Z9PPCSBAMG)

100-lt gas tilting braising pan  
with Duomat cooking surface,  
thermostatic control,  
(Watermark & AGA) - Australia

### Short Form Specification

Item No. \_\_\_\_\_

Suitable for natural gas or LPG. Burners in AISI 441 with flame failure device. Duomat cooking surface for roasting, browning, stewing, preparation of sauces, sautéing, boiling and braising. Can be installed on cantilever systems. Installation on wheels is not available. Includes mechanism to manually tilt the pan and double-skinned lid in stainless steel. Cooking temperature can be set through thermostat and the energy input through an energy regulator. Exterior panels of unit in stainless steel with Scotch Brite finish. Right-angled side edges to allow flush-fitting junction between units.

### Main Features

- Actual cooking temperature setting through adjustable thermostat.
- Manual tilting mechanism to facilitate pan emptying.
- Smooth large surfaces, easy access for cleaning.
- Double-skin well and lid to reduce heat dispersion.
- Lid is double-lined, insulated in 20/10 Stainless steel.
- Energy input controlled by energy regulator.
- The special design of the control knob system guarantees against water infiltration.
- Bratt pan ideal for sautéing, poaching, steaming, boiling, stewing and damp cooking.
- Duomat cooking surface allows to perform wet and dry cooking alternatively.
- Working temperature can be set from 80 °C to 300 °C.

### Construction

- All pan internal surfaces round and polished for better hygiene.
- All exterior panels in Stainless Steel with Scotch Brite finishing.
- Model has right-angled side edges to allow flush fitting joints between units, eliminating gaps and possible dirt traps.
- Burners in AISI 441 against corrosion and thanks to a high strength yield, are resistant to high temperature.
- Burners in chrome plated steel with flame failure device, optimized combustion and piezo ignition with electronic flame control.
- Cooking surface with **Duomat** bottom: a 10 mm-thick alloy obtained from the combination of 2 different stainless steels for better thermal stability and corrosion resistance.
- IPX5 water resistance certification.
- Usable capacity of the well 85 liters.

### Sustainability

- Heat-insulated: limited heat radiation and low energy consumption.

APPROVAL: \_\_\_\_\_

### Optional Accessories

- |  |            |                          |
|--|------------|--------------------------|
| • Draught diverter, 150 mm diameter                                      | PNC 206132 | <input type="checkbox"/> |
| • Matching ring for flue condenser, 150 mm diameter                      | PNC 206133 | <input type="checkbox"/> |
| • Flanged feet kit   | PNC 206136 | <input type="checkbox"/> |
| • Frontal kicking strip for concrete installation, 1000 mm               | PNC 206150 | <input type="checkbox"/> |
| • Frontal kicking strip for concrete installation, 1200 mm               | PNC 206151 | <input type="checkbox"/> |
| • Frontal kicking strip for concrete installation, 1600 mm               | PNC 206152 | <input type="checkbox"/> |
| • Frontal kicking strip, 1000 mm   | PNC 206177 | <input type="checkbox"/> |
| • Frontal kicking strip, 1200 mm   | PNC 206178 | <input type="checkbox"/> |
| • Frontal kicking strip, 1600 mm   | PNC 206179 | <input type="checkbox"/> |
| • Pair of side kicking strips  | PNC 206180 | <input type="checkbox"/> |
| • 2 panels for service duct (single installation)                        | PNC 206181 | <input type="checkbox"/> |
| • 2 panels for service duct (back to back installation)                  | PNC 206202 | <input type="checkbox"/> |
| • 4 feet for concrete installation (not for 900 line freestanding grill) | PNC 206210 | <input type="checkbox"/> |
| • Chimney upstand, 1000 mm   | PNC 206305 | <input type="checkbox"/> |
| • Rear paneling - 1000mm (EVO700/900)                                    | PNC 206375 | <input type="checkbox"/> |
| • Rear paneling - 1200mm (EVO700/900)                                    | PNC 206376 | <input type="checkbox"/> |
| • Chimney grid net, 200mm (EVO700&EVO900)                                | PNC 206399 | <input type="checkbox"/> |
| • Chimney grid net, 400mm  | PNC 206400 | <input type="checkbox"/> |
| • Trolley with lifting and removable tank                                | PNC 922403 | <input type="checkbox"/> |
| • Pressure regulator for gas units                                       | PNC 927225 | <input type="checkbox"/> |

**Front**

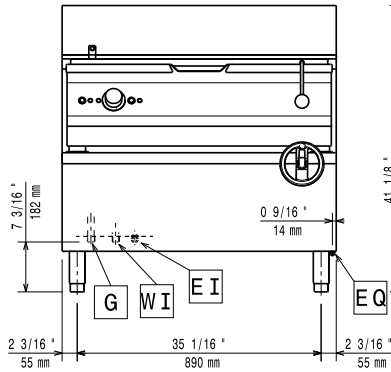

**Side**

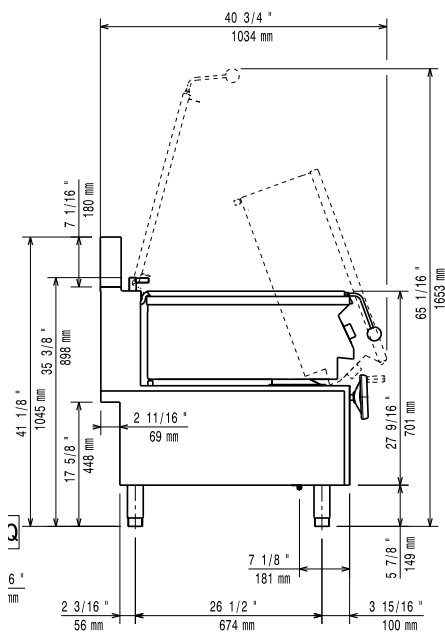

- CW11** = Cold Water inlet 1
- EI** = Electrical inlet (power)
- G** = Gas connection

**Top**

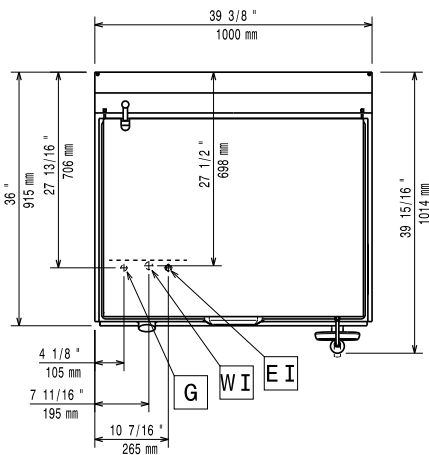

**Gas**

Natural gas - Pressure:

392427 (Z9PPCSBAMG) 7" w.c. (17.4 mbar)

LPG Gas Pressure:

11" w.c. (27.7 mbar)

Gas Power:

27 kW

Gas Type Option:

LPG; Natural Gas

Gas Inlet:

1/2"

**Key Information:**

No clearance needed on rear sides of unit if wall is of non combustible type. If wall is combustible, minimum 50 mm wall clearance should be maintained.

**Cooking Surface Depth:** 565 mm

**Cooking Surface Width:** 880 mm

**Cooking Surface Thickness:** 10 mm

**Cooking Well Height:** 180 mm

**Well Capacity, Max:** 100 lt

**Working Temperature MIN:** 80 °C

**Working Temperature MAX:** 300 °C

**Net weight:** 180 kg

**Shipping weight:** 193 kg

**Shipping height:** 1090 mm

**Shipping width:** 1080 mm

**Shipping depth:** 1020 mm

**Shipping volume:** 1.2 m<sup>3</sup>